

# ***NorthStar***<sup>TM</sup> brand

## **Instruction Manual**

Manual Number: 791-1060-00 Rev. B  
November, 2008

### **Rim Tach® RT8500 Magneto-resistive Encoder**

*Designed for use in*  
with .625" to 4.500" Thru-Shaft Applications and 1.125",  
2.125", 2.375", & 2.875" End-of-Shaft Applications

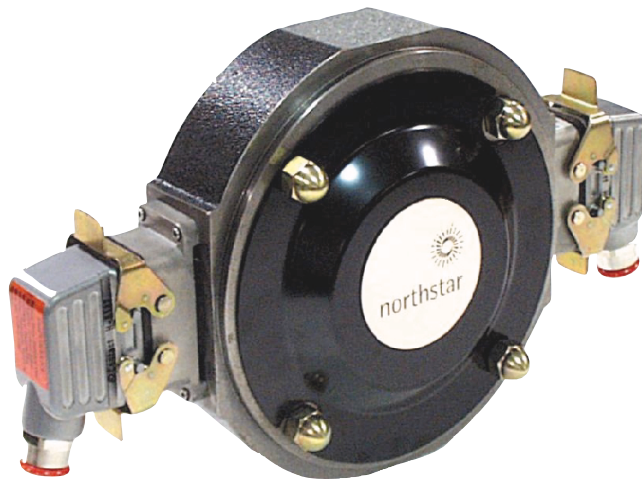



**Table of Contents and List of Illustrations**

<b>Chapter/Paragraph</b>	<b>Page</b>
<b>1.0 Introduction .....</b>	<b>4</b>
1.0 Safety Summary.....	4
1.1 General .....	5
1.2 Description .....	5
<i>Figure 1: RIM Tach® 8500 Thru-Shaft Enclosure/Sensor Physical Dimensions .....</i>	<i>5</i>
1.3 Specifications .....	6
<b>2.0 Installation .....</b>	<b>7</b>
2.0 Inspection and Unpacking.....	7
2.1 Painting Considerations.....	7
2.2 Motor Facing & Shaft .....	7
<i>Figure 2 Typical 8.5" Diameter Type C-Face Motor .....</i>	<i>8</i>
<b>3.0 Installation Instructions for Pulse Wheels .....</b>	<b>8</b>
3.1 Spoked Clamp Style Wheel and Enclosure Installation – 0.625" - 1.250" ID.....	9
<i>Figure 3: Enclosure Installation .....</i>	<i>10</i>
<i>Figure 4: RimTach 8500 Spoked Wheel Wxploded View 0.625" – 1.250" .....</i>	<i>11</i>
<i>Figure 5: Optional Pulse Wheel Alignment Check with Depth Gauge .....</i>	<i>12</i>
3.2 Ring Clamp Style Wheel and Enclosure Installation 1.375" – 3.25" ID and High Slew Wheel .....	13
<i>Figure 6: Installation of RimTach 8500 with Clamp Ring Style Wheel .....</i>	<i>13</i>
<i>Figure 7: Alignment for Clamp Ring Style Pulse Wheel.....</i>	<i>14</i>
3.3 Set Screw Wheel and Enclosure Installation 3.25" – 4.50" ID .....	15
<i>Figure 8: Pulse Wheel Alignment Check Using Straight Edge .....</i>	<i>16</i>
<i>Figure 9: Enclosure Installation .....</i>	<i>17</i>
3.4 End of Shaft Wheel and Enclosure Installation .....	17
<i>Figure 12: Pulse Wheel Assembly.....</i>	<i>18</i>
<i>Figure 13: Non-Standard End-of-Shaft Mounting.....</i>	<i>19</i>
<b>4.0 Sensor Module Installation .....</b>	<b>19</b>
<i>Figure 14: Sensor Module.....</i>	<i>20</i>
<i>Figure 15: Sensor Module(s) Installation .....</i>	<i>20</i>
<b>5.0 Electrical Installation .....</b>	<b>21</b>
Table 1. Signal Coding Table .....	21
<i>Figure 16: Quick Release Connector Installation.....</i>	<i>22</i>
<b>6.0 Returning Equipment to Dynapar .....</b>	<b>23</b>

Methods and apparatus disclosed and described herein have been developed solely on company funds of Dynapar. No government or other contractual support or relationship whatsoever has existed which in any way affects or mitigates proprietary rights of Dynapar in these developments. Methods and apparatus disclosed herein may be subject to U.S. Patents existing or applied for. Dynapar reserves the right to add, improve, modify, or withdraw functions, design modifications, or products at any time without notice. Dynapar shall not be liable for errors contained herein or for incidental or consequential damages in connection with furnishing, performance, or use of this material.

**CHAPTER 1**

## INTRODUCTION

### 1.0 Safety Summary

High current, voltage, and rotating parts can cause serious or fatal injury. The use of electric machinery, like all other uses of concentrated power and rotating equipment, may be hazardous. In stalling, operating, and maintaining electric machinery should be performed by qualified personnel, in accordance with applicable provisions of the National Electrical Code and sound local practices. Failure to comply with these precautions or with specific warnings elsewhere in this manual violates safety standards of design, manufacture, and intended use of the instrument. ©Dynapar assumes no liability for the customer's failure to comply with these requirements.

#### Rotating Machinery

Avoid contact with rotating parts. Avoid by-passing or rendering inoperative any safety guards or protection devices. Avoid extended exposure in close proximity to machinery with high noise levels. Use proper care and procedures in handling, lifting, installing, operating and maintaining the equipment.

#### Before Installation

Safe maintenance practices with qualified personnel is imperative. Before starting maintenance procedures, be positive that, (1) equipment connected to the shaft will not cause mechanical rotation, (2) main machine windings have been disconnected and secured from all electrical power sources, and (3) all accessory devices associated with the work area have been de-energized. If high potential insulation test is required, follow procedures and precautions outlined in NEMA standards MG-1.

#### Grounding

Improperly grounding the frame of the machine can cause serious or fatal injury to personnel. Grounding of the machine frame and structure should comply with the National Electrical Code and with sound local practices. Check wiring diagram before connecting power.

#### Do Not Operate In An Explosive Atmosphere

Do not operate the instrument in the presence of flammable gases or fumes. Operating any electrical instrument in such an environment constitutes a definite safety hazard.

#### Keep Away From Live Circuits

Operating personnel must not remove instrument covers. Component replacement and internal adjustments must be made by qualified maintenance personnel. Do not replace components with power cable connected. To avoid injuries, always disconnect power and discharge circuits before touching them.

#### Do Not Substitute Parts Or Modify Instrument

Do not install substitute parts or perform any unauthorized modification to the instrument. Introducing additional hazards is dangerous. Return the instrument to an authorized Dynapar representative for service and repair to ensure that safety features are maintained.



**CAUTION!:** Crucial information, that *must* be read and followed regarding safety and unit functioning.



**DO THIS!:** Additional procedure, that must be read and followed, without safety issues.



**NOTE:** Useful information that should be read.



**QUESTION:** Helpful hints to answer your possible questions.

## 1.1 General

These instructions do not claim to cover all details of variation in equipment or to provide for every possible contingency or hazard to be met in connection with installation, operation, and service. Should further information be desired or should particular problems arise which are not covered sufficiently for the purchaser's purposes, please contact Dynapar, or one of its designated representatives.

## 1.2 Description

The RIM Tach® 8500 (and henceforth 8500 Quad) is a high performance, reliable Digital Tachometer, designed to provide position and velocity feedback from both AC and DC electric motors with pulse counts ranging from 60 through 1200 pulses per revolution.



The RIM Tach® 8500 allows up to 2 sensor modules, whereas the Rim Tach® 8500 Quad allows up to 4.

Designed for NEMA 180 through 500 diameter AC or DC motor frames, the RIM Tach 8500 utilizes rugged ductile iron casting construction, and provides interchangeable sensor modules and a magneto-resistive technology capable of withstanding the harshest in dustrial environments. This ensures a precise and consistent digital motor speed feedback.

The NorthStar RIM Tach® 8500 is mounted directly to the motor frame and utilizes a patent pending, heavy-duty, one piece, magneto-resistance sensor module with encapsulated surface mount electronics. The encapsulation provides resistance to water, oil mist, dirt, high temperatures, and other harsh environments. The sensor module includes a 10-pin quick connector requiring only a screwdriver for final electrical installation. The non-contact magneto-resistive sensor and rugged magnetized pulse wheel are redesigned and machined to function properly without any adjustments when assembled to a NEMA 180 type C/F ace (8.5- inch diameter) motor frame and accessory mount. There are no bearings to fail or requirements for flexible couplings since the magnetized pulse wheel assembly is attached directly to the shaft. The RIM Tach 8500 provides precise, reliable speed signals for many monitoring and control applications, and is a standard feedback device for AC and DC variable speed drives. The unit is bi-directional providing square wave outputs.

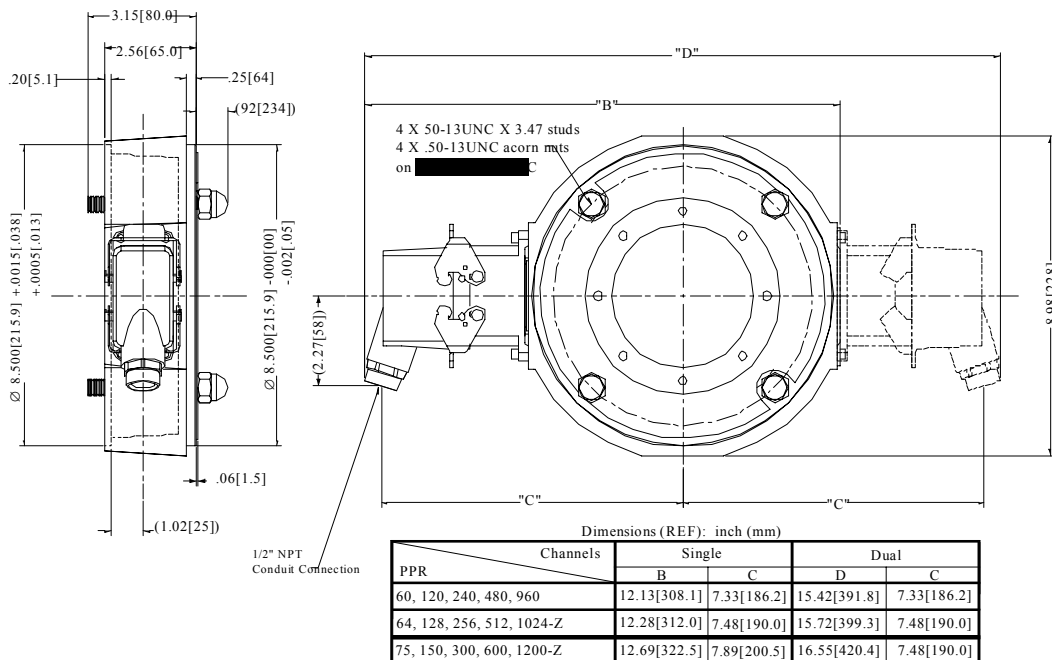

Figure 1: RIM Tach® 8500 Thru-Shaft Enclosure/Sensor Physical Dimension

## 1.3 Specifications

Electrical Specifications	
Frequency Response	0 - 120 kHz
Pulse Code	A, B, Z (Index), and complements (A, B, Z)
Output Phases	A, B phase @quadrature: 90° phase, Z phase: One per rev. (gated)
Pulse Duty Cycle	50% ± 15% (within defined mechanical specifications)
Quadrature Accuracy	90° ± 22° (within defined mechanical specifications)
Output Type	High speed, differential driver
Rise and Fall Time	Less than 1µs @ 10,000 pf typical load
Current Consumption	45 mA typical plus line driver load
Output Current	150 mA maximum continuous
ESD Protection	2kV
Mechanical Specifications	
Maximum Operational Speed	7,000 RPM or 120 kHz
Nominal Air Gap	0.019 ± 0.008"
Shaft Axial End Play	Up to ± 0.050"
Enclosure Configuration	8.5-inch diameter 180 C motor face or accessory flange to meet NEMA MG1-4 standards
Slew Rate	3,600 RPM/second 12,000 RPM (with optional high slew rate pulse wheel)
Enclosure Material	Ductile iron casting
Sensor Module	Stainless Steel
Approximate Weight	25lb.
Dimensions	22" X 12" X 9"
Environmental Specifications	
Operational Temperature	-40° to +80° C
Operational Humidity Range	Minimum of 90%
Chemical Resistance	Salt spray, most solvents, mild acids and bases
Vibration	Minimum 18 g's RMS, 5-2000 Hz shock spectrum
Shock (Sensor Module)	1 meter drop tested, min. 30g's
Interface Specifications	
Power	+5.0 to +15.0 VDC
Output	Differential output swinging between Vcc - 0.6V and Ground
Connector	10 pin industrial latching connector with ½ inch NPT fitting, IP-65 NEMA 4, 12 rated
Suggested Cable	22 - 16 AWG, 10 conductor, shielded, twisted pair

Specifications subject to change without notice.

## CHAPTER 2 INSTALLATION

## 2.0 Inspection and Unpacking

Inspect shipping container for external damage. All claims for damage (apparent or concealed) or partial loss of shipment must be made in writing to Dynapar within (5) days from receipt of goods. If damage or loss is apparent, please notify the shipping agent immediately.

Open shipping container and locate the packing list. The packing list is included to verify that all components, accessories, and manual were received. Please use the packing list to check off each item as the unit is unpacked. Inspect for damage. Dynapar recommends that the shipping container be retained for future shipping, storage, or return to factory purposes.

If any equipment was damaged in transit, be sure to file proper claims promptly with the carrier and insurance company. Please advise Dynapar of such filing. In case of parts shortages, advise Dynapar immediately. Dynapar cannot be responsible for any missing parts unless notified within 60 days of shipment.

## 2.1 Painting Considerations

The enclosure may be painted. Please pay attention to the following considerations.

- Do not hinder the latches on the connector if the connector is painted.
- If the enclosure is painted before the sensor module(s) is added, be sure to mask off the area where the sensor module(s) will be placed. The module must mate directly to the enclosure. Failure to do this will degrade the alignment of the system and may cause it to fail.
- Ensure excess paint runoff does not clog Enclosure drain holes.

## 2.2 Motor Facing and Shaft

The RIM Tach<sup>®</sup> 8500 has been designed to be mounted on a 8.5 inch diameter 180 C Flange that meets or exceeds the NEMA MG1-4 Standards. To prepare the motor facing and shaft for installation, perform the following steps.

Clean outer rim and surface of motor facing and shaft of paint, grease, dirt and other debris where RIM Tach<sup>®</sup> 8500 unit contacts motor or accessory. Also ensure that mating surfaces have not been damaged and that unit will fit squarely on motor.



Ensure there is no paint, burrs, protrusions, or deformations on the motor facing or shaft. If the enclosure does not fit squarely on the motor facing, the alignment between the sensor module and the magnetic pulse wheel may be degraded.

Apply a thin layer of corrosion preventative or oil to motor facing and shaft to aid assembly and provide some corrosion protection.

Ensure motor facing and shaft are free from paint, burrs, protrusions, and deformations

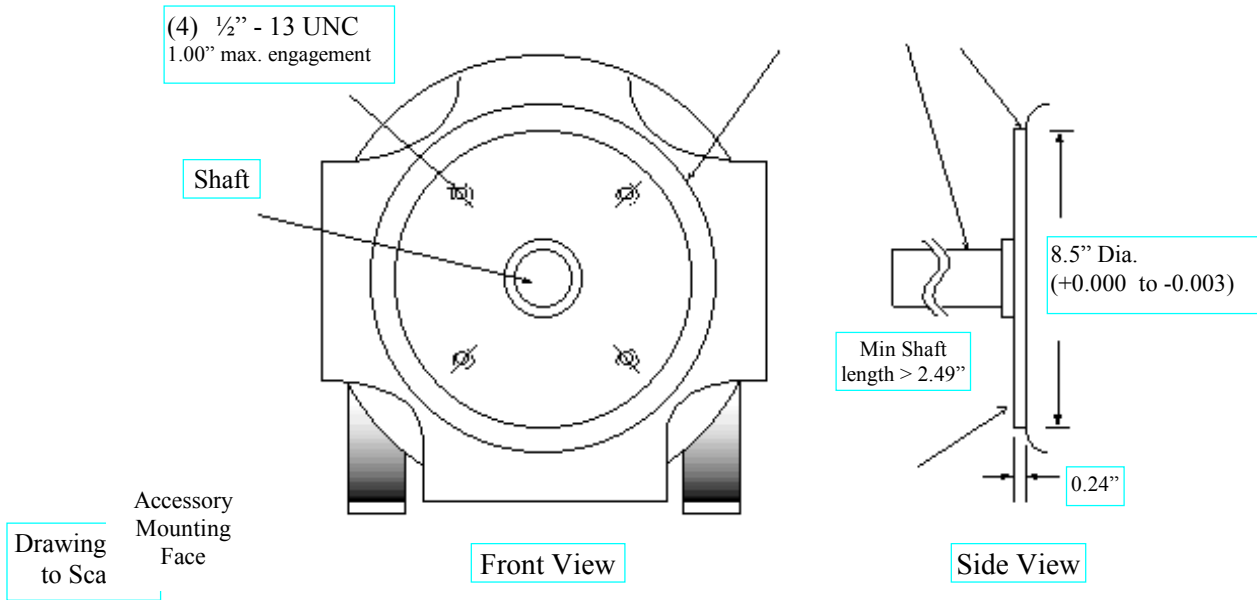

Figure 2 : Typical 8.5" Diameter Type C-Face Motor



**3.0 VERIFY THE TYPE OF WHEEL YOUR APPLICATION WILL USE. EACH STYLE OF WHEEL HAS IT'S OWN INSTALLTION METHOD TO ENSURE PROPER ALIGNMENT WITH THE SENSOR.**

- 3.1 Thru Shaft - Spoked/Clamp Style Wheel – 0.675" – 1.25" ID
- 3.2 Thru Shaft - Ring Clamp Style Wheel – 1.375" – 3.250" ID and High Slew Pulse Wheels
- 3.3 Thru – Shaft Set Screw Style Wheel – 3.256" – 4.50" ID
- 3.4 End of Shaft Style Wheel – 1.125", 2.125" 2.375" & 2.875" ID of Shaft

### 3.1 Directions for Installing Spoked/Clamp Wheel and Enclosure 0.625” – 1.250” ID

#### Pulse Wheel and Enclosure Installation



Caution must be used when handling the pulse wheel assembly. The surface of the pulse wheel outer rim is sensitive to scratches and impacts. The magnetic properties of the pulse wheel material can also be distorted or erased by exposure to strong magnetic fields.

Remove pulse wheel assembly from packaging.

Slide pulse wheel onto motor accessory shaft. Be sure to position the pulse wheel so that the letter ‘Z’ or the sticker ‘THIS SIDE OUT’ is visible from the mounting face. Do not tighten.



Do not attempt to mount or dismount the enclosure with sensor probe module(s) installed. Remove all sensor modules until enclosure mounting is complete.

Insert four ½-12 mounting studs so that the inside threaded portion is completely threaded into the motor frame. This will set the mounting stud to the correct length. Torque the mounting studs to a nominal 60 ft-lbs. The mounting studs support the weight of the enclosure during installation, permit better alignment to the motor, and prevent the Pulse Wheel from being damaged.

Remove enclosure from packaging.

Determine which of two orientations of enclosure is best for this application (Sensor Modules horizontal or vertical).



Ensure that one of two drain holes is at bottom of enclosure. If not, rotate the unit 180°.

Insert the four alignment screws all the way into the 8500 housing. The 4 (10-32 UNC) alignment screws are screwed into the cover screw holes. For this to be done, the cover must be removed. The pulse Wheel will not be lined up properly if the cover is on the 8500. These standoff screws are used to exactly position the pulse wheel under the sensor module.

Place enclosure on rods and slide on to motor facing. Tap lightly with hand or hammer if needed to start enclosure to slide over motor facing. Make sure clearance holes remain aligned.



Do not damage the pulse wheel when mounting the enclosure. If the pulse wheel assembly is not far enough down the shaft, continue pushing it on with the enclosure until the enclosure seats.

Insert four 1/2-13 cap nuts onto the remaining exposed mounting studs. Tighten the nuts in an alternating star pattern.

Continue alternating and tightening until enclosure is seated. Torque all cap nuts to a nominal 50 ft-lbs.

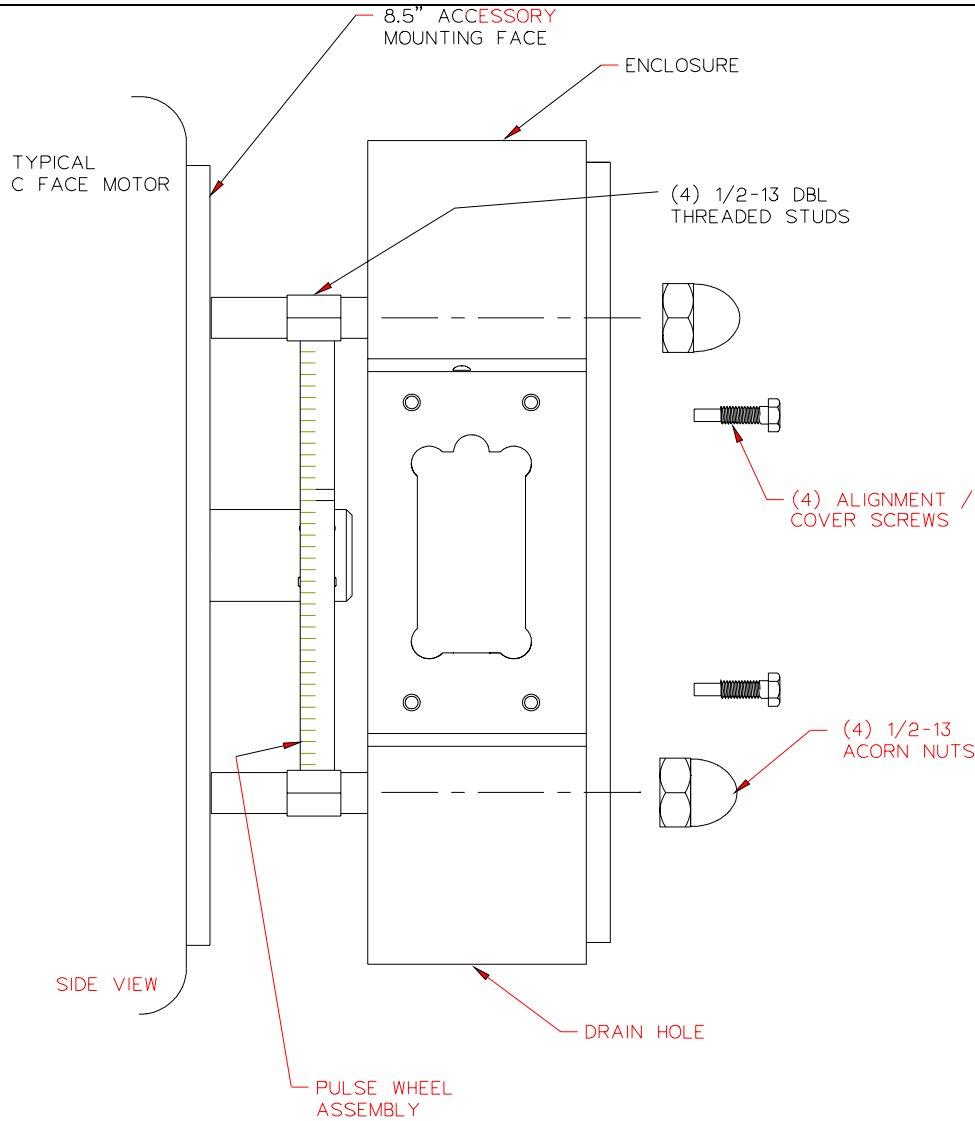
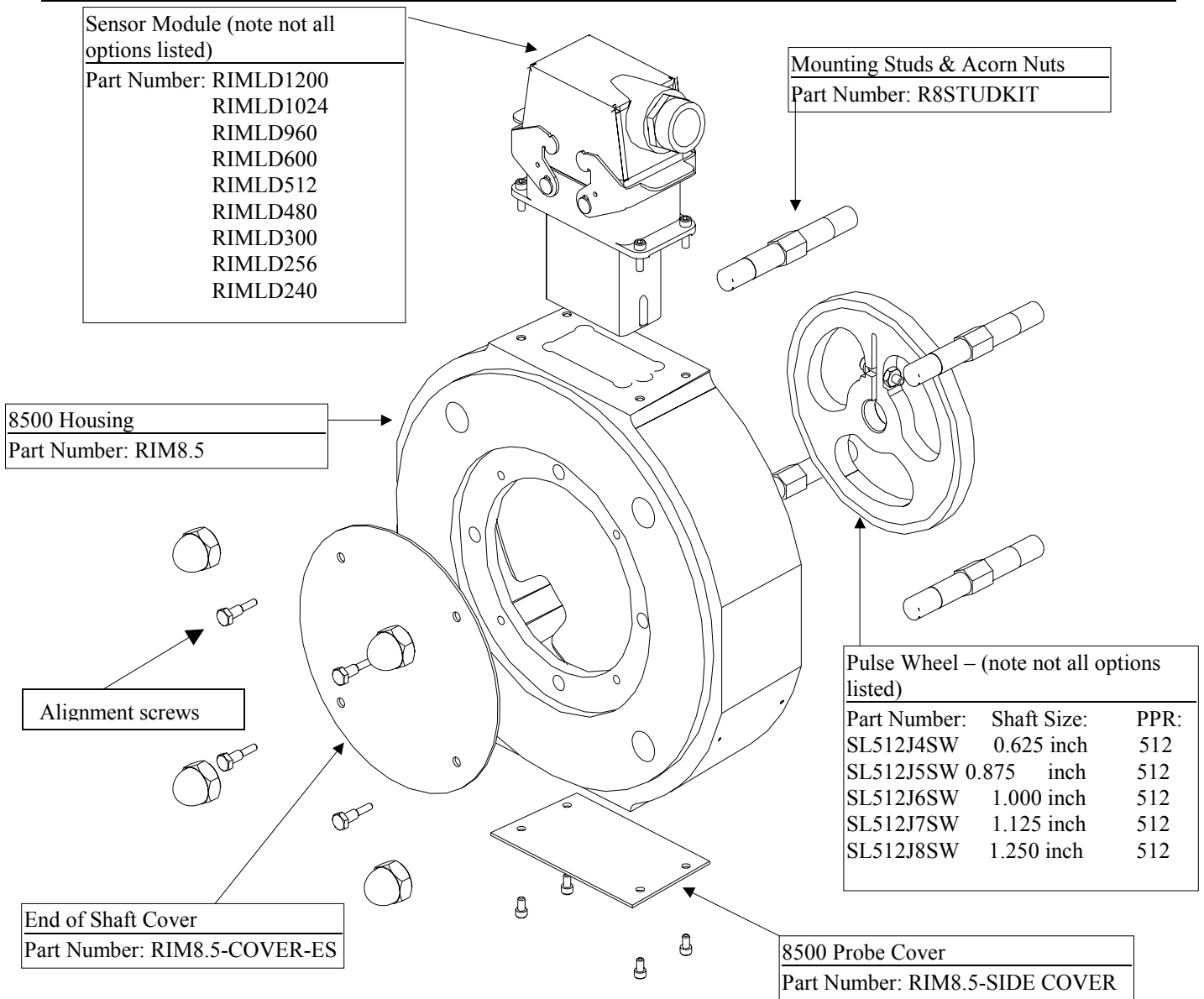

**Figure 3: Enclosure Installation**

Pull pulse wheel forward so it touches all four alignment screws in the housing. This will position the pulse wheel into the correct axial alignment.

Tighten the #8 socket head cap screw to a nominal 5 ft-lbs. **One full turn after the clamp begins to grip the shaft will provide full holding power. Do not overtighten the pulse wheel.** Use the 9/64 inch hex wrench supplied with the unit. Make sure the pulse wheel is touching all the alignment screws as the pulse wheel is being tightened.

Once the wheel is securely tightened on the shaft, remove the four alignment screws from the enclosure. Now the cover can be placed on the enclosure or discarded, depending on your application. If you will be using the cover, use the standoff screws to secure the cover to the enclosure.



**Figure 4: RimTach<sup>®</sup> 8500 Spoked Wheel Exploded View 0.625" – 1.250" ID**

### Optional Pulse Wheel Alignment Check

Locate four 5/16-inch diameter access holes on recessed area in the face of the enclosure. Pulse Wheel inspection holes are located on a 4.63 diameter Bolt Center (BC).

Using a calibrated depth measuring tool (vernier caliper, depth gauge, etc.), measure through inspection hole to obtain distance between recessed surface on enclosure and aluminum magnetic ring underneath.

Repeat for all four access holes. Take an average of all four readings.



The range (difference between high and low measurements) of readings should be less than 0.010 inch (0.255mm). If the range of the readings is greater, the pulse wheel is not perpendicular to the shaft and will appear to

wobble during shaft rotation. Tap the edge of the pulse wheel to bring it back in line.

The distance between the surface of the recess in the face of the enclosure and the pulse wheel assembly should be  $\pm 0.015$  inch (0.380mm). If the measurement does not correspond to this depth, the position of the pulse wheel assembly must be adjusted.

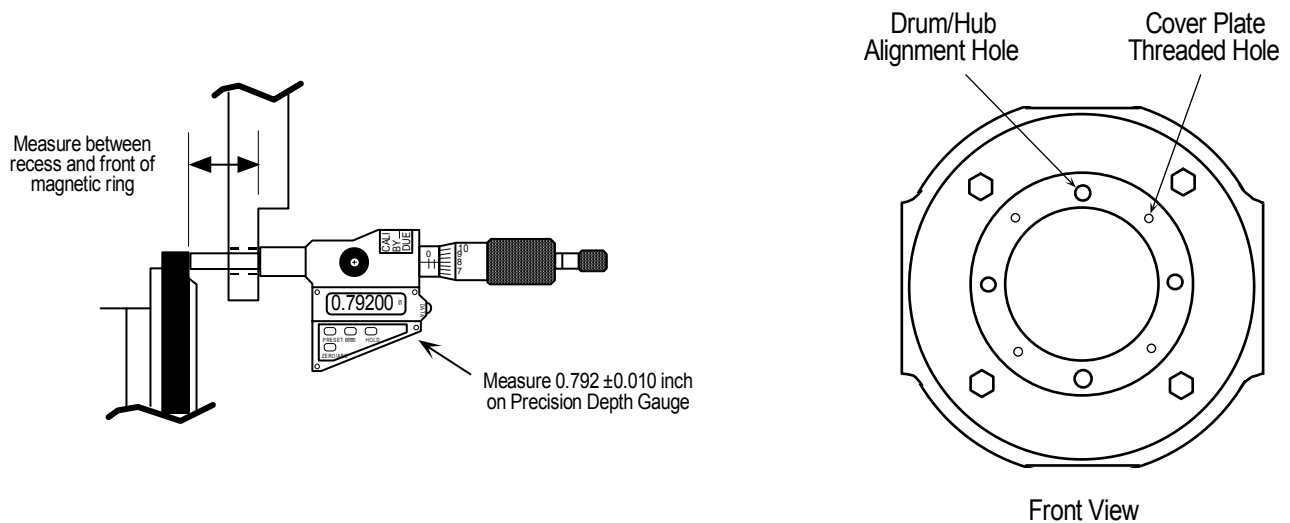

*Figure 5: Optional Pulse Wheel Alignment Check with Depth Gauge*

### 3.2 Directions for Installing Ring Clamp Wheel and Enclosure 1.375" – 3.25" ID and High Slew Pulse Wheels

## Pulse Wheel and Enclosure Installation



Caution must be used when handling the pulse wheel assembly. The surface of the pulse wheel outer rim is sensitive to scratches and impacts. The magnetic properties of the pulse wheel material can also be distorted or erased by exposure to strong magnetic fields.

Remove pulse wheel assembly from packaging.

Push the pulse wheel along the motor shaft until there is approximately a one inch gap between the inner face of the pulse wheel and the motor face.

Push the wire ring along the shaft until it is seated into the pulse wheel's chamfer.

Push the clamping plate along the shaft until it is flush against the wire ring.

Align the clearance holes in the clamping plate with the threaded holes of the pulse wheel.

Insert screws and tighten, to snug, by hand.

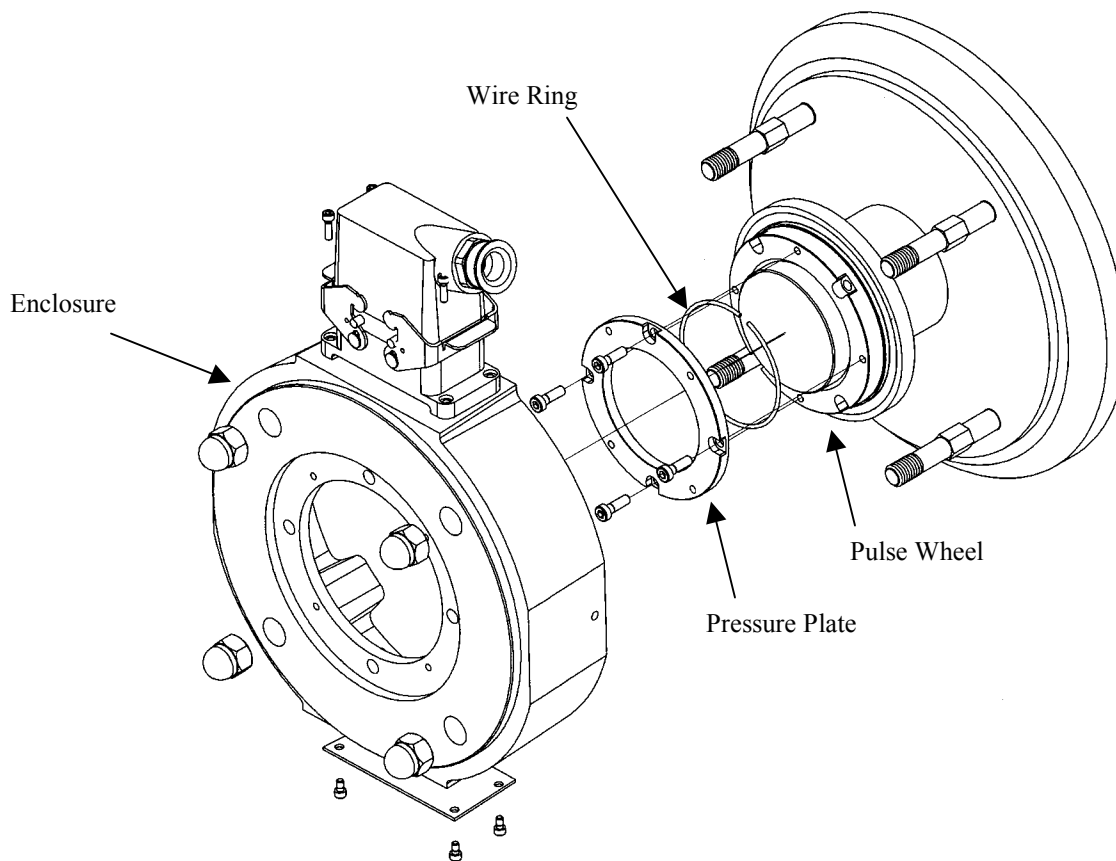

*Figure 6: Installation of RIMTACH 8500 with Clamp Ring Style Wheel*



**Please note** Figure 6 shows sensor module mounted to enclosure. Sensor Module is the last step in the installation process. Do not install enclosure with module in place!



Do not damage the pulse wheel when mounting the enclosure. If the pulse wheel assembly is not far enough down the shaft, continue pushing it on with the enclosure until the enclosure seats.

Insert four 1/2-12 mounting studs so that the inside threaded portion is completely threaded into the motor frame. This will set the mounting stud to the correct length. Torque the mounting studs to a nominal 60 ft-lbs. The mounting studs support the weight of the enclosure during installation, permit better alignment to the motor, and prevent the Pulse Wheel from being damaged.

Remove enclosure from packaging.

Determine which of two orientations of enclosure is best for this application (Sensor Modules horizontal or vertical).



Ensure that one of two drain holes is at bottom of enclosure. If not, rotate the unit 180°.

Place enclosure on rods and slide on to motor facing. Tap lightly with hand or hammer if needed to start enclosure to slide over motor facing. Make sure clearance holes remain aligned.

Using a straight edge, align the pulse wheel so that the front edge of the pressure plate is even with the recess of the enclosure. See figure 7.

Once the pulse wheel is aligned, tighten the screws in a star pattern to 30 inch-pounds.



Do not attempt to mount or dismount the enclosure with sensor probe module(s) installed. Remove all sensor modules until enclosure mounting is complete.

Insert four 1/2-13 cap nuts onto the remaining exposed mounting studs. Tighten the nuts in an alternating star pattern. Continue alternating and tightening until enclosure is seated. Torque all cap nuts to a nominal 50 ft-lbs.

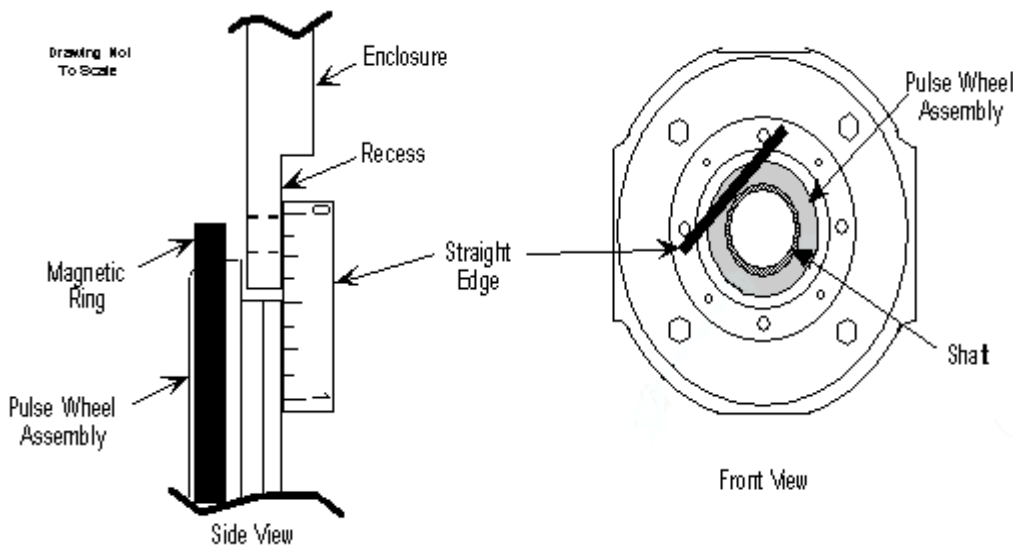

Figure 7: Alignment for Clamp Ring Style Pulse Wheel

### 3.3 Directions for Installing Set Screw Wheel and Enclosure 3.25” – 4.50” ID

#### Pulse Wheel and Enclosure Installation



Caution must be used when handling the pulse wheel assembly. The surface of the pulse wheel outer rim is sensitive to scratches and impacts. The magnetic properties of the pulse wheel material can also be distorted or erased by exposure to strong magnetic fields.

Remove pulse wheel assembly from packaging.

Leave protective red rubber band in place over pulse wheel.

Place assembly over the end of the shaft. The wheel side with the two set screws should be toward the outside, away from motor.



Be sure the set screws in the adapter are retracted so that they will not interfere with the shaft while mounting the unit.

Slide assembly on the shaft until there is about a 1 inch gap left between inner face of pulse wheel and motor facing. It may be necessary to lightly tap the assembly to get it all the way on. The 1 inch gap is not a critical measurement.

Insert four ½-12 mounting studs so that the inside threaded portion is completely threaded into the motor frame. This will set the mounting stud to the correct length. Torque the mounting studs to a nominal 60 ft-lbs. The mounting studs support the weight of the enclosure during installation, permit better alignment to the motor, and prevent the Pulse Wheel from being damaged.

Remove enclosure from packaging.

Determine which of two orientations of enclosure is best for this application (Sensor Modules horizontal or vertical).



Ensure that one of two drain holes is at bottom of enclosure. If not, rotate the unit 180°.

Place enclosure on rods and slide on to motor facing. Tap lightly with hand or hammer if needed to start enclosure to slide over motor facing. Make sure clearance holes remain aligned.

If the pulse wheel is not lined up and **no pre-drilled holes** are required, use the following procedure to adjust the position of the pulse wheel.

Slide the pulse wheel assembly until the alignment surface of the unit is even with the recess in the face of the enclosure.

Use a straight edge to check it. The alignment surface and recess of the enclosure should be aligned to within ±0.010”.

See figure 8.

Tighten two set screws to a nominal 15 inch-pounds.

If the pulse wheel is not lined up and **pre-drilled holes** are desired, use the following optional procedure to locate (or relocate) set screw holes in shaft.

Leaving one of the set screws tightened, remove other set screw and use a punch to mark position of set screw hole on shaft.

Replace and tighten set screw. Remove other set screw and use a punch to mark position of that set screw hole on shaft.

Remove enclosure and pulse wheel.

Use standard ¼” bit to drill a hole that is approximately 0.1” deep from the tangent point of shaft (point of first contact of drill to shaft) to bottom of hole. Do this for both holes.

Slide pulse wheel back onto motor shaft.

Slide the enclosure back onto four ½-12 mounting studs reseating enclosure to the 8 ½” C-Face.

Slide the pulse wheel assembly until the alignment surface of the unit is even with the recess in the face of the enclosure.

Use a straight edge to check it. The alignment surface and recess of the enclosure should be aligned to within ±0.010”.

See figure 8.

Tighten two set screws to a nominal 15 inch-pounds.



If pre-drilled screw holes turn out to be incorrectly placed, new screw holes must be drilled. New holes may be drilled plus or minus the error distance from the old holes.



Do not attempt to mount or dismount the enclosure with sensor probe module(s) installed. Remove all sensor modules until enclosure mounting is complete

Insert four 1/2-13 cap nuts onto the remaining exposed mounting studs. Tighten the nuts in an alternating star pattern. Continue alternating and tightening until enclosure is seated. Torque all cap nuts to a nominal 50 ft-lbs. See figure 10.

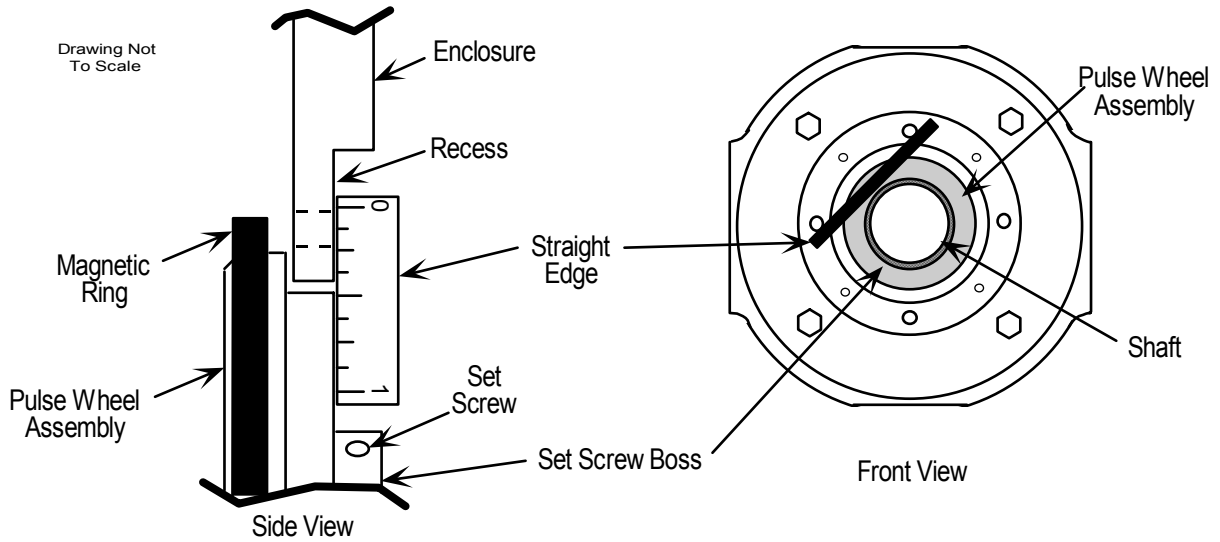
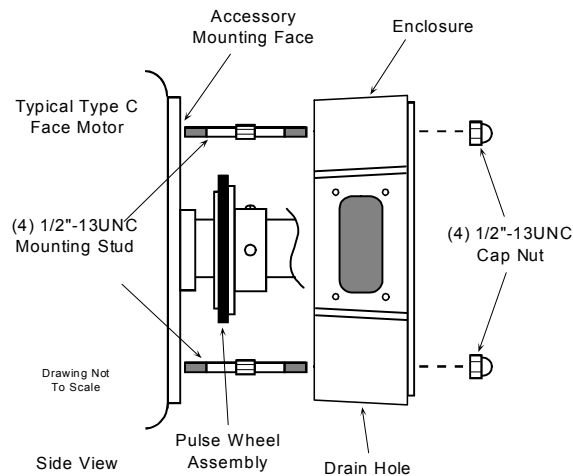

Figure 8: Pulse Wheel Alignment Check Using Straight Edge



*Figure 9: Enclosure Installation*

### 3.4 Directions for Installing End-Of-Shaft Pulse Wheel and Enclosure



Caution must be used when handling the pulse wheel assembly. The surface of the pulse wheel outer rim is sensitive to scratches and impacts. The magnetic properties of the pulse wheel material can also be distorted or erased by exposure to strong magnetic fields.

Remove pulse wheel assembly from packaging. Leave protective red rubber band in place over pulse wheel.

Place one spacer washer into the shaft recess of the pulse wheel. See figure 12.



The pulse wheel is designed to use one spacer washer for a motor shaft length of  $0.400 \pm 0.010$  inch. If the motor shaft is a different length, please refer to section titled 'Non Standard End-Of-Shaft Mounting Procedure' for axial adjustment procedure.

Place pulse wheel shaft recess over the end of the motor shaft. Rotate the wheel so that the mounting bolt holes line up with the shaft tapped holes. Press the wheel assembly onto the shaft until it seats. Light tapping on the steel hub may be required.



Some motor shafts do not have anti-rotation mounting holes. Instead, they have only one center tapped hole. For these cases, please review the Non-Standard End-of-Shaft Mounting Procedure.

Insert and snug mounting bolts into the wheel. If the pulse wheel has not already seated, alternate tightening each bolt until it is seated. (E01 Pulse Wheel [1.125 inch shaft] units require only one center mounting bolt. After complete tightening the pulse wheel, tighten the 10-32 anti-rotation set screw.)

Tighten each bolt to the proper torque: 15 foot-pounds for 10-24 bolts, and 30 foot-pounds for 3/8-16 bolts.



The pulse wheel should be seated flat against the motor shaft. The wheel should not appear to wobble if the motor shaft is turned by hand. Excessive wobble (0.020" TIR) can damage the pulse wheel and sensor modules.

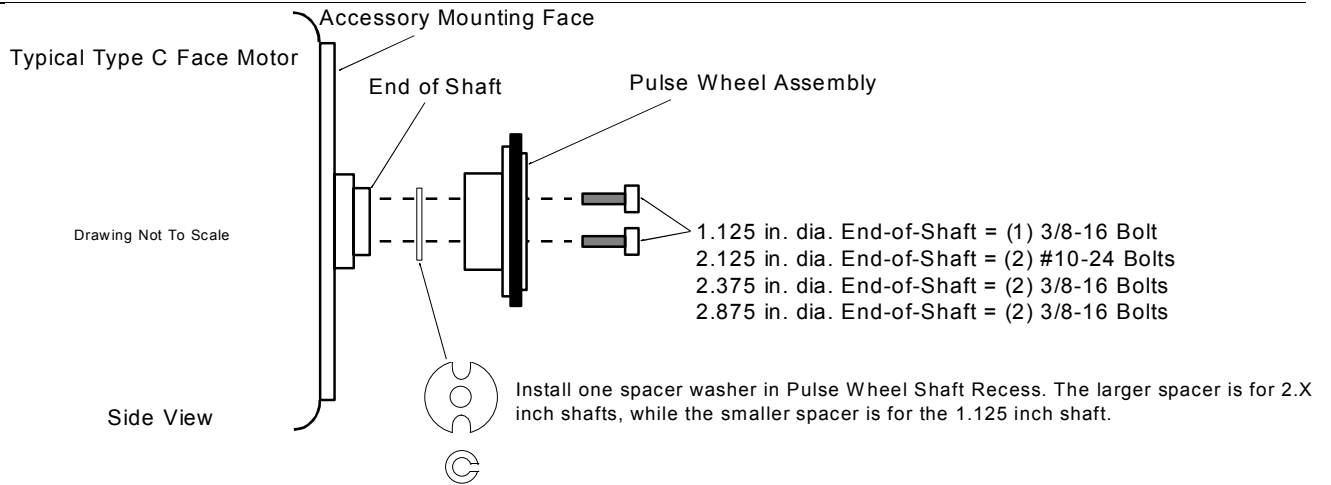

**Figure 12: Pulse Wheel Assembly**

### Non-Standard End-of-Shaft Mounting Procedure

For mounting on a non-standard end-of-shaft, perform the following steps (see Figure 13).



The pulse wheel is designed to use one spacer washer for a motor shaft length of  $0.400 \pm 0.010$  inch. If the motor shaft is a different length, please refer to Section 2.2.6 for axial position adjustment.

Select the appropriate bolt to go through the center hole of the pulse wheel and into the center tapped motor shaft.

Place pulse wheel shaft recess over the end of the motor shaft.

Insert center mounting bolt through pulse wheel center into motor shaft. Tighten so that the pulse wheel sits completely flat against the motor shaft. Tighten to specified torque value for bolt.



This securely holds the pulse wheel onto the motor shaft. However, some measure of pulse wheel anti-rotation should be taken.

Drill through the anti-rotation holes of the pulse wheel into the motor shaft.

Insert a roll pin sized to snugly fit the pulse wheel anti-rotation hole, through the pulse wheel, and into the motor shaft.



The pulse wheel should be seated flat against the motor shaft. The wheel should not appear to wobble if the motor shaft is turned by hand. Excessive wobble can damage the pulse wheel and sensor modules.

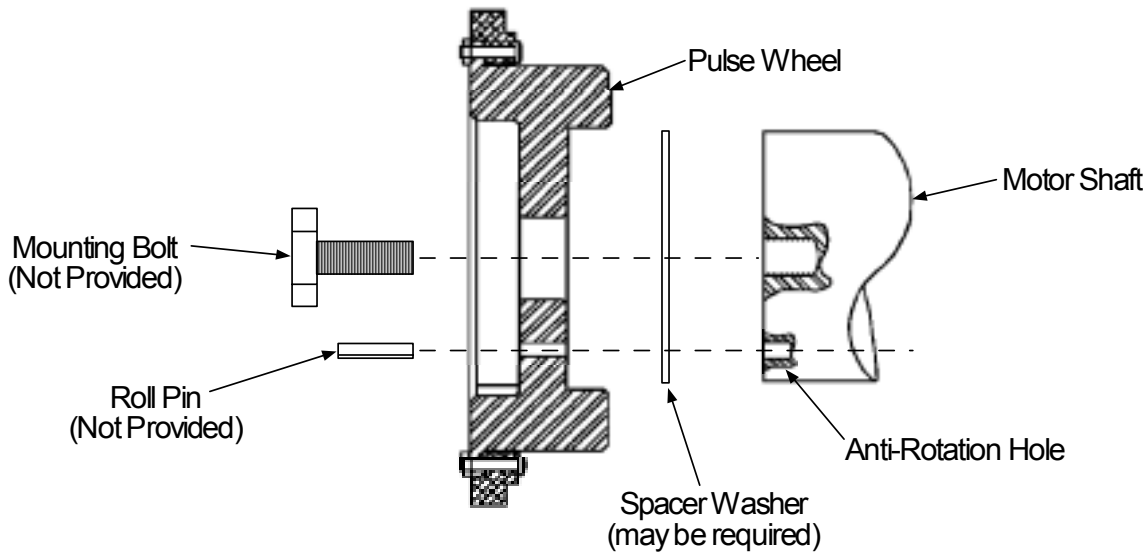

Figure 13: Non-Standard End-of-Shaft Mounting

## 4.0 Sensor Module Installation

To install the Sensor Module, perform the following steps. See Figure 15.

Remove sensor module and mating connector from packaging.



Although the device is protected from Electrostatic Discharges up to 2000 Volts, standard ESD precautions should be followed.

Separate mating connector from sensor module by releasing the two latches.



Use caution when handling the sensor module. The sensor at the end of the module can be easily damaged by sharp objects. The sensor module can be damaged by sudden shocks (dropping, hammer blows, etc.).

Insert sensor module into opening in enclosure. The sensor assembly is keyed to ensure proper orientation (blue side goes toward motor facing).

Locate four socket head cap screws. Insert socket head cap screws through clearance holes in sensor module and into tapped holes in enclosure. Tighten to a nominal 5 inch-pounds.



There should not be a gap between the lip on the housing and the enclosure. The stainless steel sensor module is designed to seat in metal-to-metal contact with the enclosure. Ensure that no gaskets, paint, dirt, etc., interferes with the complete seating of the module in the enclosure.

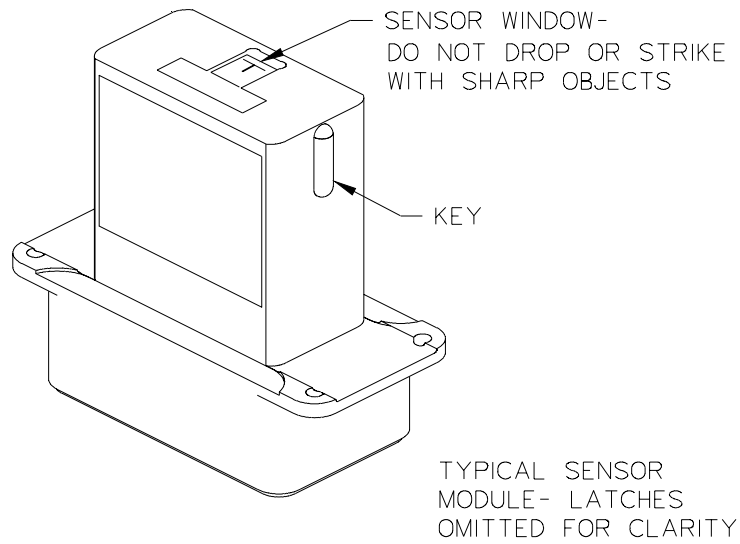

**Figure 14: Sensor Module**

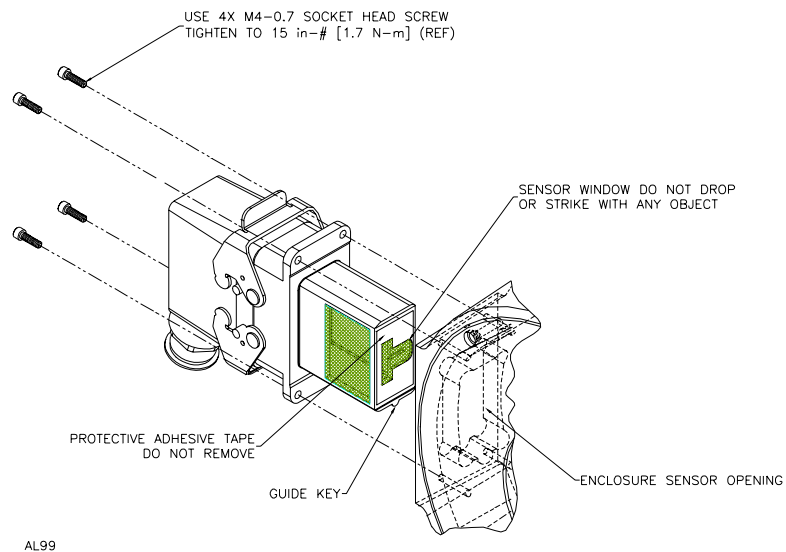

**Figure 15: Sensor Module(s) Installation**



There should not be a gap between the lip on the housing and the enclosure. The stainless steel sensor module is designed to seat in metal-to-metal contact with the enclosure. Ensure that no gaskets, paint, dirt, etc., interfere with the complete seating of the module in the enclosure.

## 5.0 Electrical Installation

Electrical connections are made to the sensor module through a standard 1/2 inch NPT liquid tight flexible conduit. The nipple length may be changed to extend the outlet box if desired.

Interconnection cable recommendations are as follows: stranded copper, 22 through 16 gage, braided or foil with drain wire shielding 0.05  $\mu$ F maximum total mutual or direct capacitance, outer sheath insulated. Shrink tubing may be placed over any wires bare of insulation. For lengths over 100 feet, use 18 gage or larger, to a maximum of 1000 feet. If shielded twisted pair wire is used, do not cross channels. Keep each pair of complementary channel outputs together in a single twisted pair (e.g., A and A complement).



Reversing power and common will not damage the unit. However, applying power to any of the sensor outputs may cause damage.

### Quick Release Connector Hood Wiring

To install the Quick Release Connector, perform the following steps.

Remove the four screws from the mating connector housing that hold the terminal block in place. Remove terminal block from housing.

Insert wiring through liquid tight flexible seal and mating connector housing. Leave enough wire exposed to comfortably reach the terminal block.

Wire to terminal block according to wire code in Table 1. A similar wiring list is attached to enclosure.

Table 1. Signal Coding Table

Signal	Connector Pin	Pigtail Cable	MS Connector
Common	1	Black	A
B	2	Green	E
A	3	Blue	D
Z *	4	Violet	C
No Connection	5	----	----
Vcc (5-15 VDC)	6	Red	B
/B	7	Yellow	H
/A	8	Gray	G
/Z *	9	Orange	I
Shield	10	Braid/Clear	J

Applies only to units with index pulse capability.



The connector hood has two orientations. The terminal block can be inserted either way so the connector hood points up or down. Choose the direction best for your application. The shield in the sensor module is isolated from the frame of the encoder for maximum noise immunity. The shield wire or pin should be connected to the shield on the drive.

Tighten liquid tight fitting on housing. **OPTIONAL:** In some hostile environments, seal between connector body and Sensor Module can be improved by smearing a sealant (silicone grease, etc.) on the neoprene seal of the connector.

Mate connector into place on sensor mount and snap two latches into place. If only one sensor is being installed, ensure cover plate is installed over other sensor hole.

The wire colors shown on the chart are for the sensors with wire cables instead of connectors.

The MS connector pin-outs are for the sensors with the MS connector. The female portion of the connector must be soldered by the customer.

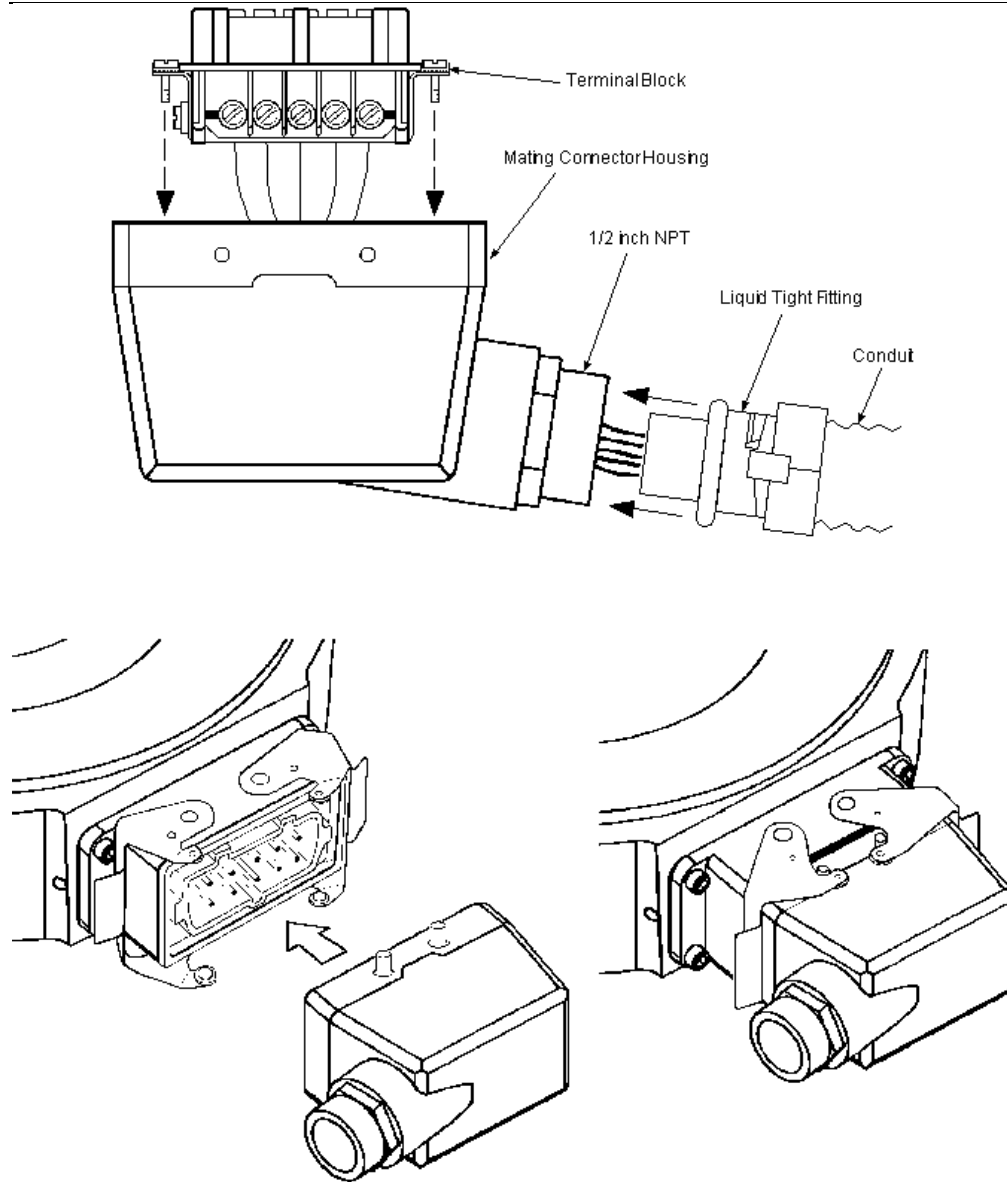

*Figure16 : Quick Release Connector Installation*

## 6.0 Returning Equipment to Dynapar

If it is necessary to return the unit for repair or replacement, a Return Goods Authorization (RGA) number must be obtained from a factory representative before returning the equipment to our service department. When returning an instrument for service, the following information must be provided before Dynapar can attempt any repair.

1. Instrument model and serial number
2. User's name, company, address, and phone number
3. Malfunction symptoms
4. Description of system
5. Returned Goods Authorization number

Consult the factory for shipping instructions.

